

Note that all unique customer requirements (i.e tolerance) need to be verified thru Alfa Laval.

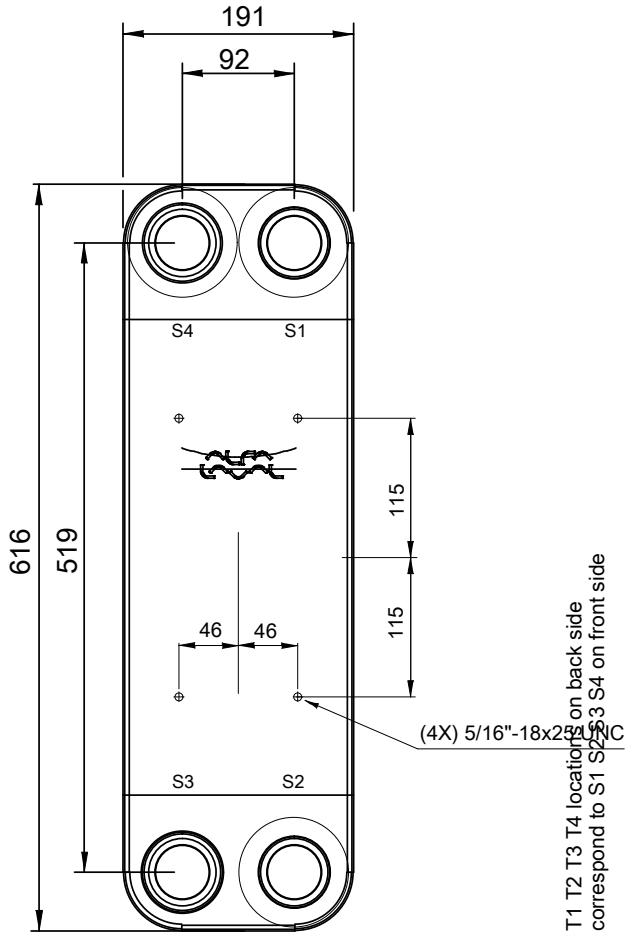
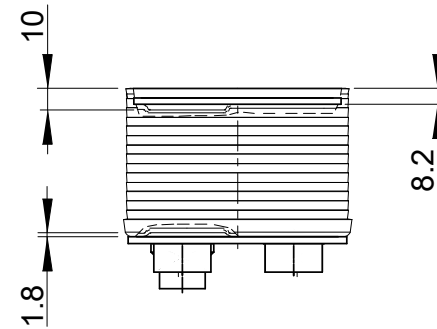
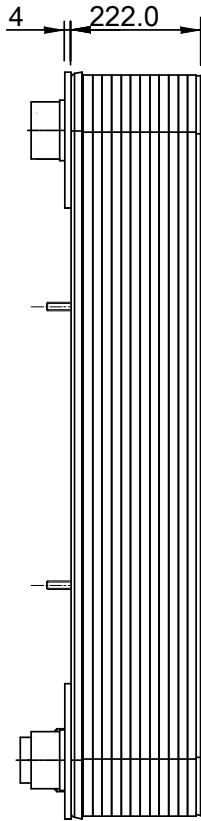
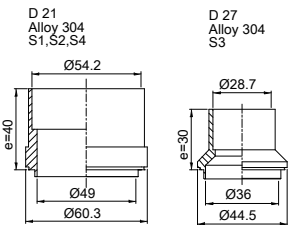

T1 T2 T3 T4 locations on back side correspond to S1 S2 S3 S4 on front side

HEATING SURFACE
 NETWEIGHT 49.3 kg
 OPERATING WEIGHT
 PLATE MATERIAL Alloy 316
 PLATE GROUPING 1*49AMH/1*50AML

ALL DIMENSIONS IN MILLIMETERS

SIDE	MEDIA	INLET	TEMP.	OUTLET	TEMP.	FLOW RATE	PRESSURE DROP	LIQUID VOL.
1								7.84 dm ³
2								10 dm ³



PRESSURE VESSEL APPROVAL UL/CRN
 ACH220EQ-100AM-F S62 (3287155311)

www.alfalaval.com

CUSTOMER NAME / REF. NO.
 COMPANY / REF.

TOTAL LENGTH 262.0 mm
 TOTAL WIDTH 190.0 mm
 TOTAL HEIGHT 616.0 mm

3/15/2017
 REV 0